

GT-250

Indoor gas burner, for professional use.

Sturdier, more powerful and with a bigger gas circulation area. Safety valve with built-in thermocouple.

Perfect for cooking paella or rice dishes, and to use with large pots, pans, stills and distillation devices. Specially designed for the restaurant, small artisan food industries and microbreweries.

Patented Optim System

Greater gas flow.
Stronger and richer fire.
Flame positioned laterally.
Higher flame reach.
Better combustion.

NEW!!!

THREE-POSITION TAP (for shut-off, high and for very precise low position thanks to the Minimum System).

Models certified according to European Regulation UE 2016/426 and European Standards UNE EN 497 and UNE EN 203-1 and UNE EN 203-2-1.

OFF Turn off position

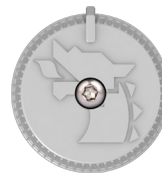

ON Maximum

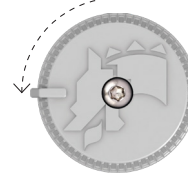

Minimum System

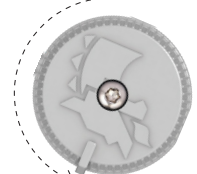

Minimum System. Allows precise control of very low flame, easing the cooking process.

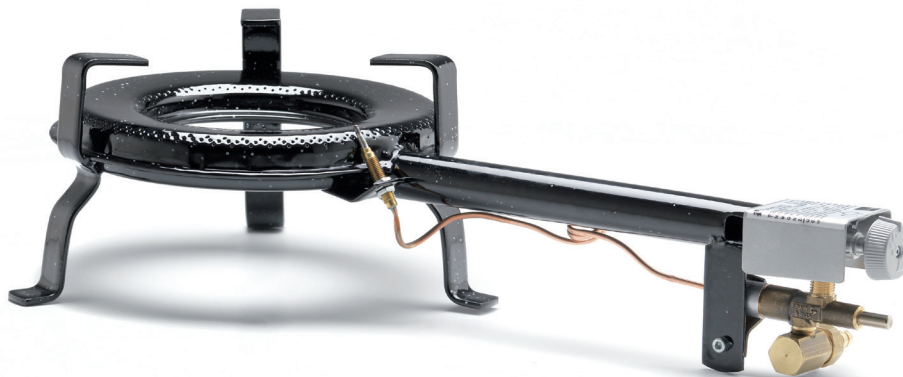

GT-250



Model 1	Gas (mbar) / Power (kw)	Butane	29 mbar / 7,00 kw
		Propane	37 mbar / 7,00 kw
Model 2	Gas (mbar) / Power (kw)	Propane	50 mbar / 11,20 kw (only approved for gas bottles)
Model 3	Gas (mbar) / Power (kw)	Natural gas	20 mbar / 9,50 kw
Gas stove diameter		25 cm	
Recommended cooking pot diameter		35 to 50 cm	
Cooking volume capacity 		25 to 50 l	
Recommended maximum weight		up to 100 kg*	

OBSERVATIONS

BUTANE

The burner must be connected to a butane gas bottle by means of a flexible tube. This tube, which must not be out of date, will be clamped to the burner at one end and to the 30 mbar regulator attached to the bottle at the other end.

PROPANE

Gas installation: The burner must be connected to the installation by means of a standard hose. It is recommended to contact an authorized gas installer if a suitable installation has not been prepared.

Propane bottles: The burner must be connected to a propane gas bottle by means of a flexible tube. This tube, which must not be out of date, will be clamped to the burner at one end and to the 37 or 50 mbar regulator attached to the bottle at the other end.

NATURAL GAS

Must be connected to a gas installation by means of a standard hose. It is recommended to contact an authorized gas installer if a suitable installation has not been prepared.

⚠ VERY IMPORTANT. The gas burner must be used by professionals and in perfectly ventilated interiors. Do not use the burner with gas other than that for which it is intended. * For higher weight, we recommend the use of additional support.

GT-250

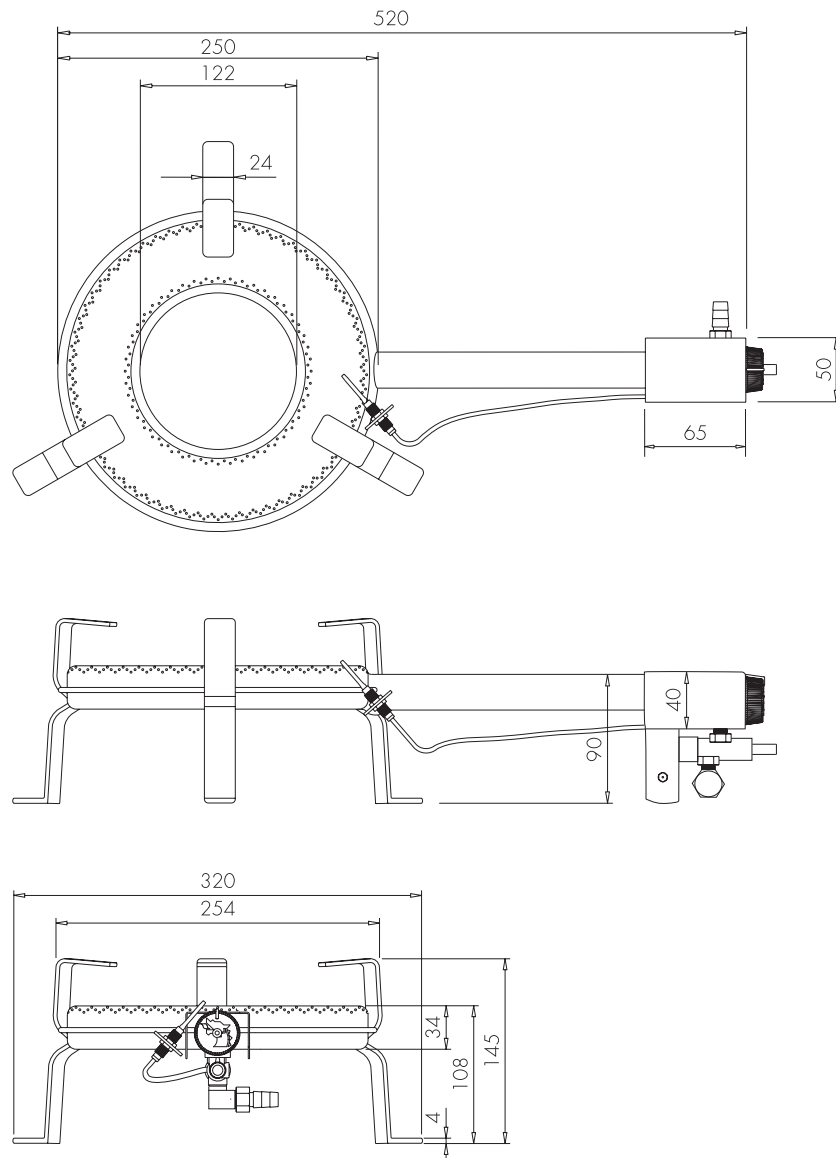

Optimgas S.L.

Pol. Industrial Sur, parcela 29
 46230 Alginet, Valencia - Spain
 T. +34 96 175 35 56 / +34 96 175 13 04
 info@flamesvlc.com

artesanía
 comunitat valenciana

GENERALITAT
 VALENCIANA
 Conselleria de Economia
 Sostenible, Sectores Productivos,
 Comercio y Trabajo

CE 1
 3
 1
 2

MADE
 SPAIN